

# Cool Room & Portable Buildings

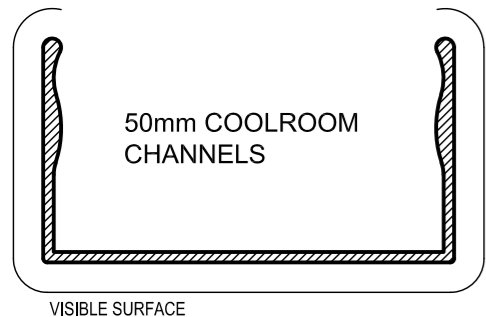

DESCRIPTION	MASS	AP	PP
CH5 CR11 50mm COOLROOM CHANNEL	0.507 kg/m	229	121
ALC070 50mm COOLROOM CHANNEL	0.497 kg/m	229	117
ALC070L 50mm COOLROOM CHANNEL	0.477 kg/m	227	120

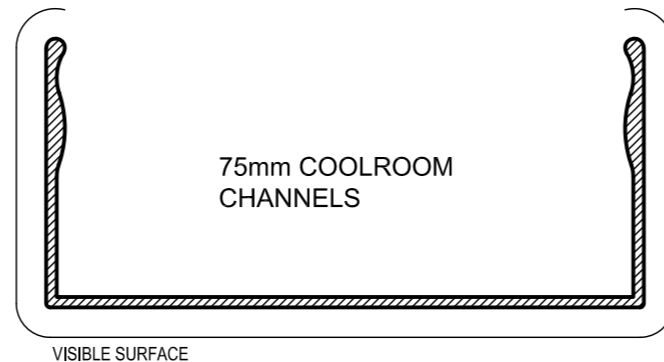

DESCRIPTION	MASS	AP	PP
CR12 75mm COOLROOM CHANNEL	0.672 kg/m	312	161
ALC071 75mm COOLROOM CHANNEL	0.642 kg/m	302	154
ALC071L 75mm COOLROOM CHANNEL	0.625 kg/m	302	157

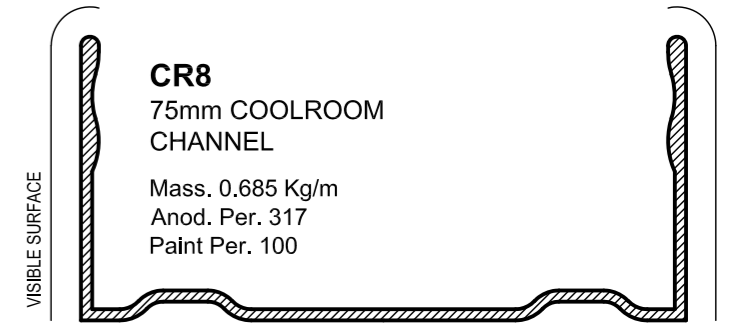

**CR8**  
75mm COOLROOM CHANNEL  
Mass. 0.685 Kg/m  
Anod. Per. 317  
Paint Per. 100

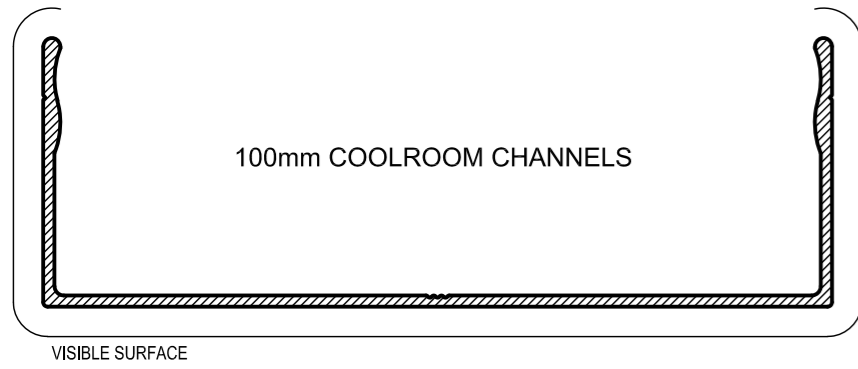

DESCRIPTION	MASS	AP	PP
CR13 100mm COOLROOM CHANNEL	0.774 kg/m	361	185
ALC072 100mm COOLROOM CHANNEL	0.741 kg/m	351	179
ALC072L 100mm COOLROOM CHANNEL	0.723 kg/m	354	184

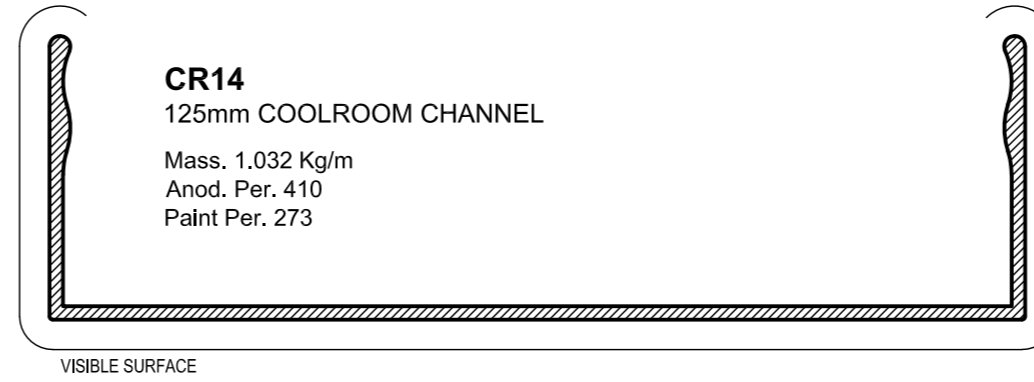

**CR14**  
125mm COOLROOM CHANNEL  
Mass. 1.032 Kg/m  
Anod. Per. 410  
Paint Per. 273

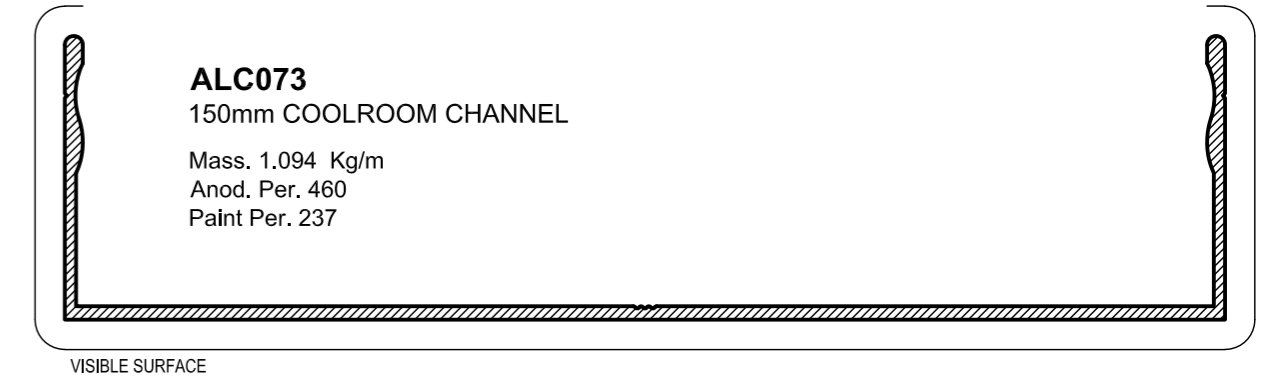

**ALC073**  
150mm COOLROOM CHANNEL  
Mass. 1.094 Kg/m  
Anod. Per. 460  
Paint Per. 237

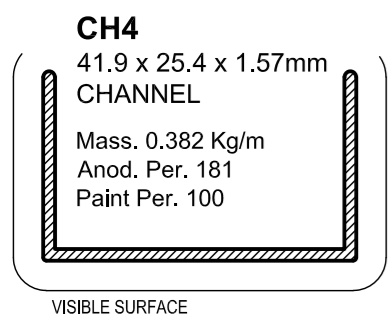

**CH4**  
41.9 x 25.4 x 1.57mm CHANNEL  
Mass. 0.382 Kg/m  
Anod. Per. 181  
Paint Per. 100

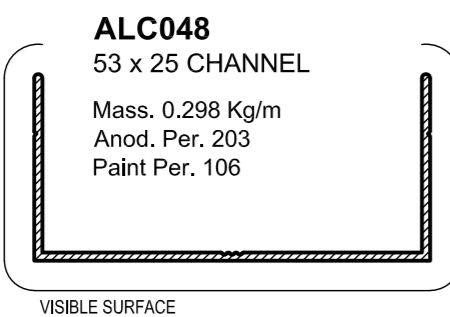

**ALC048**  
53 x 25 CHANNEL  
Mass. 0.298 Kg/m  
Anod. Per. 203  
Paint Per. 106

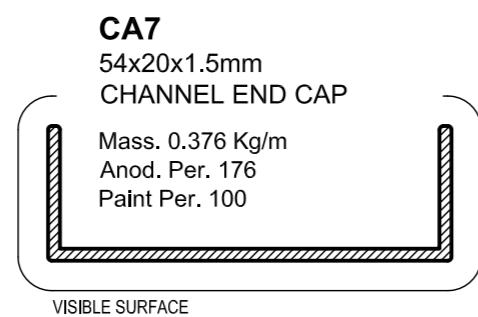

**CA7**  
54x20x1.5mm CHANNEL END CAP  
Mass. 0.376 Kg/m  
Anod. Per. 176  
Paint Per. 100

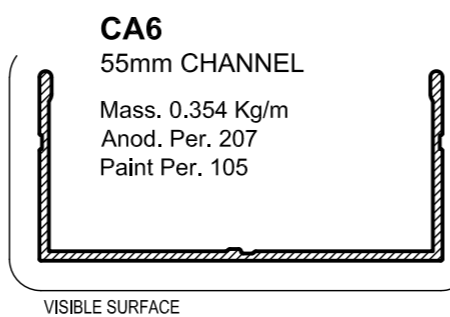

**CA6**  
55mm CHANNEL  
Mass. 0.354 Kg/m  
Anod. Per. 207  
Paint Per. 105

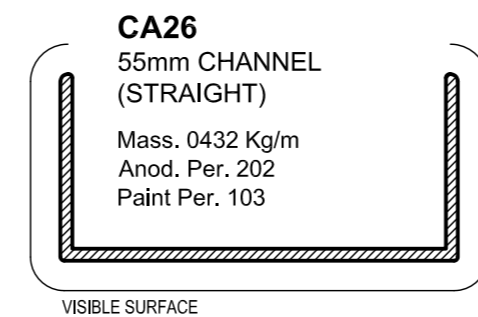

**CA26**  
55mm CHANNEL (STRAIGHT)  
Mass. 0.432 Kg/m  
Anod. Per. 202  
Paint Per. 103

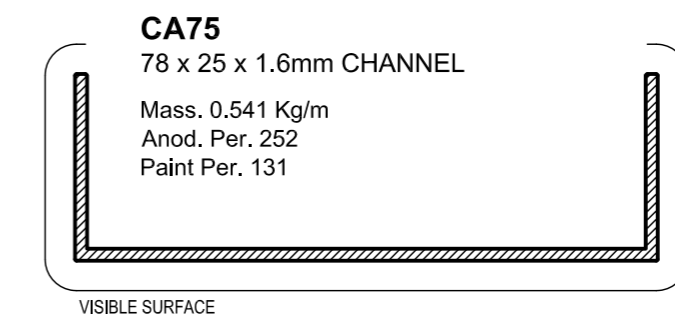

**CA75**  
78 x 25 x 1.6mm CHANNEL  
Mass. 0.541 Kg/m  
Anod. Per. 252  
Paint Per. 131



**ALC074**  
100mm COOLROOM CHANNEL  
Mass. 0.755 Kg/m  
Anod. Per. 354  
Paint Per. 182

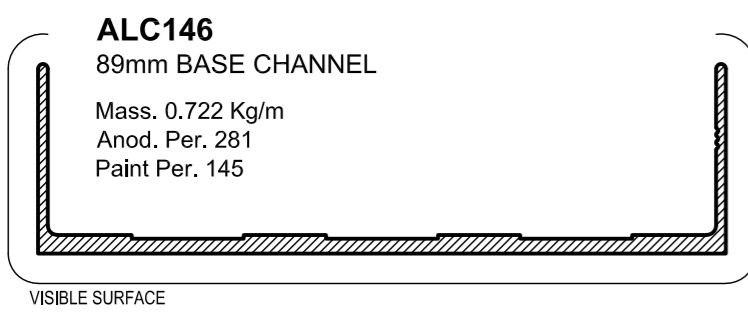

**ALC146**  
89mm BASE CHANNEL  
Mass. 0.722 Kg/m  
Anod. Per. 281  
Paint Per. 145

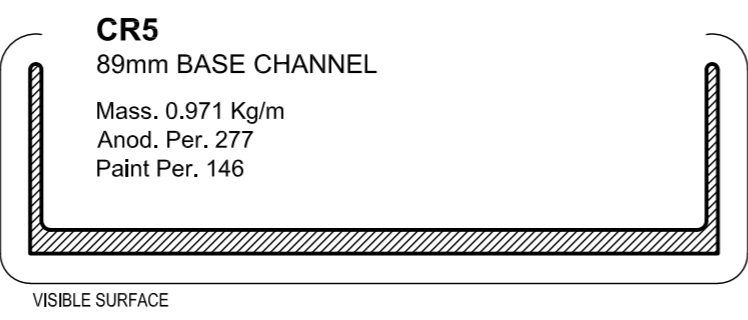

**CR5**  
89mm BASE CHANNEL  
Mass. 0.971 Kg/m  
Anod. Per. 277  
Paint Per. 146

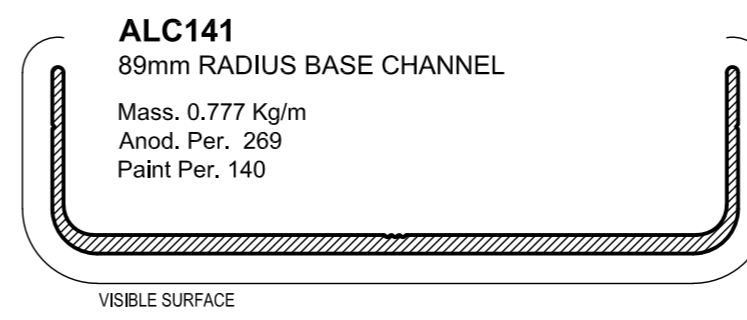

**ALC141**  
89mm RADIUS BASE CHANNEL  
Mass. 0.777 Kg/m  
Anod. Per. 269  
Paint Per. 140

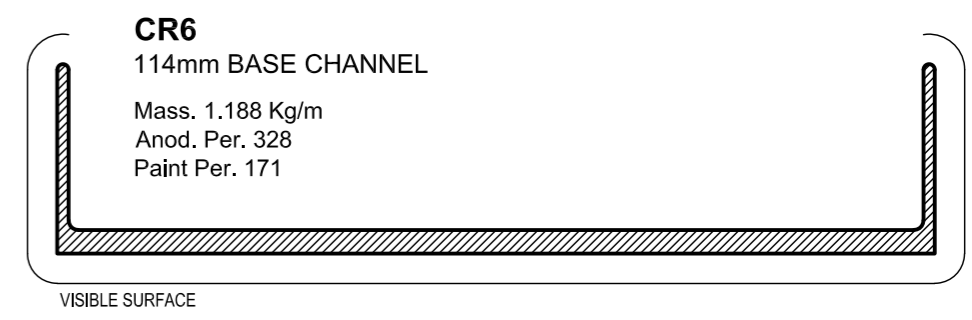

**CR6**  
114mm BASE CHANNEL  
Mass. 1.188 Kg/m  
Anod. Per. 328  
Paint Per. 171

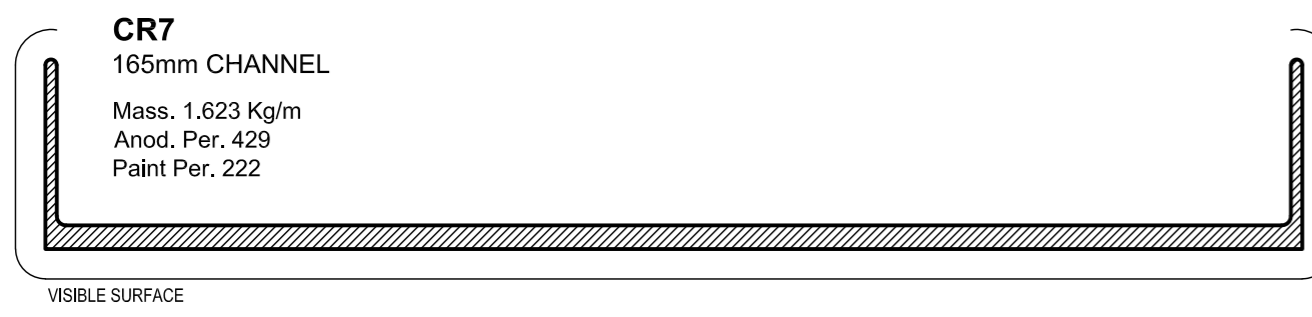

**CR7**  
165mm CHANNEL  
Mass. 1.623 Kg/m  
Anod. Per. 429  
Paint Per. 222

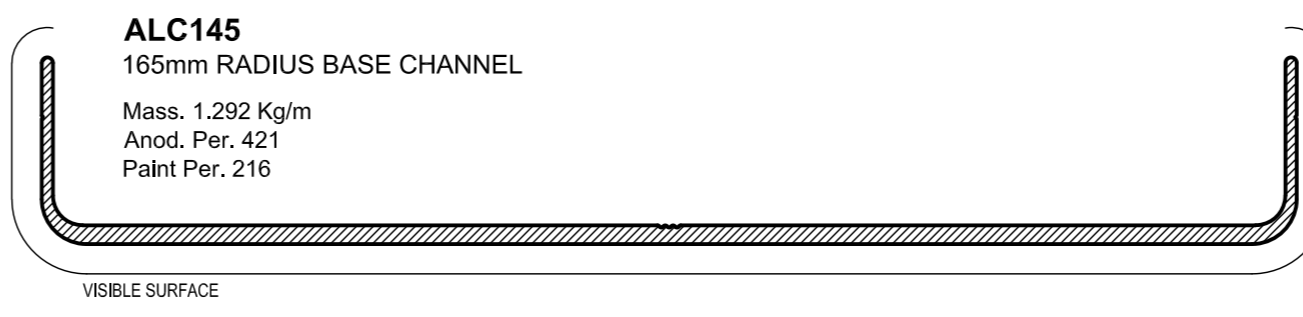

**ALC145**  
165mm RADIUS BASE CHANNEL  
Mass. 1.292 Kg/m  
Anod. Per. 421  
Paint Per. 216

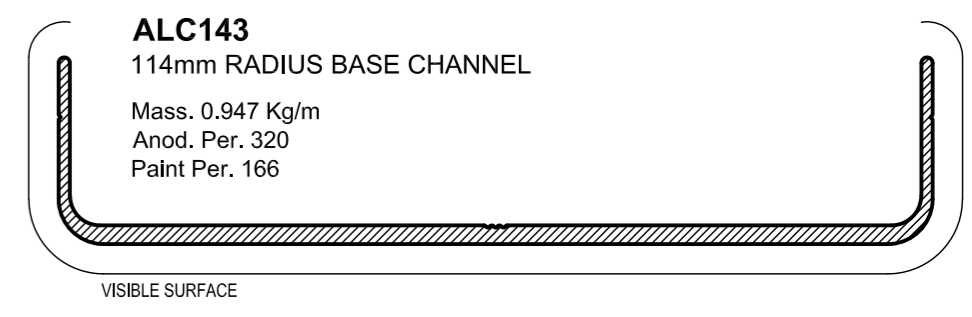

**ALC143**  
114mm RADIUS BASE CHANNEL  
Mass. 0.947 Kg/m  
Anod. Per. 320  
Paint Per. 166

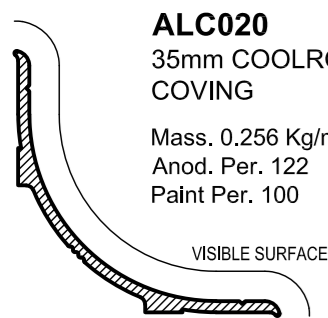

**ALC020**  
35mm COOLROOM COVING  
Mass. 0.256 Kg/m  
Anod. Per. 122  
Paint Per. 100

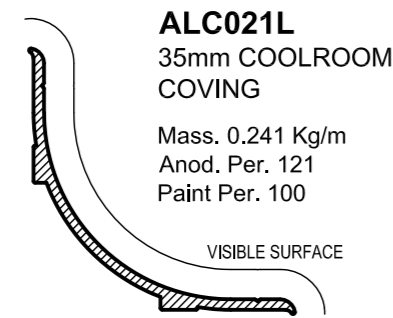

**ALC021L**  
35mm COOLROOM COVING  
Mass. 0.241 Kg/m  
Anod. Per. 121  
Paint Per. 100

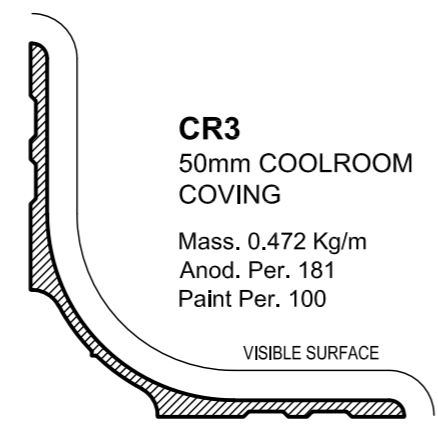

**CR3**  
50mm COOLROOM COVING  
Mass. 0.472 Kg/m  
Anod. Per. 181  
Paint Per. 100

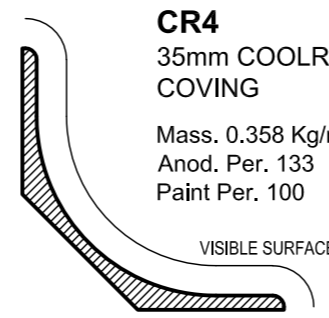

**CR4**  
35mm COOLROOM COVING  
Mass. 0.358 Kg/m  
Anod. Per. 133  
Paint Per. 100

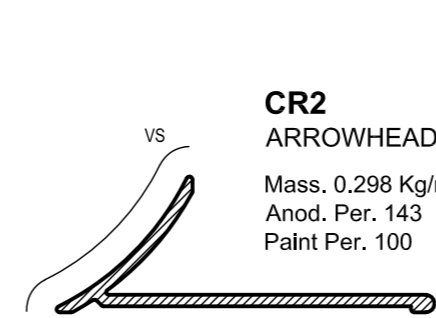

**CR2**  
ARROWHEAD  
Mass. 0.298 Kg/m  
Anod. Per. 143  
Paint Per. 100

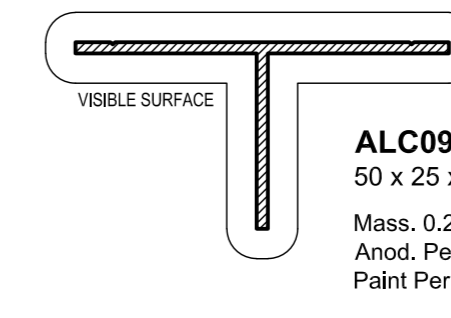

**ALC091**  
50 x 25 x 1.5mm TEE  
Mass. 0.297 Kg/m  
Anod. Per. 150  
Paint Per. 150

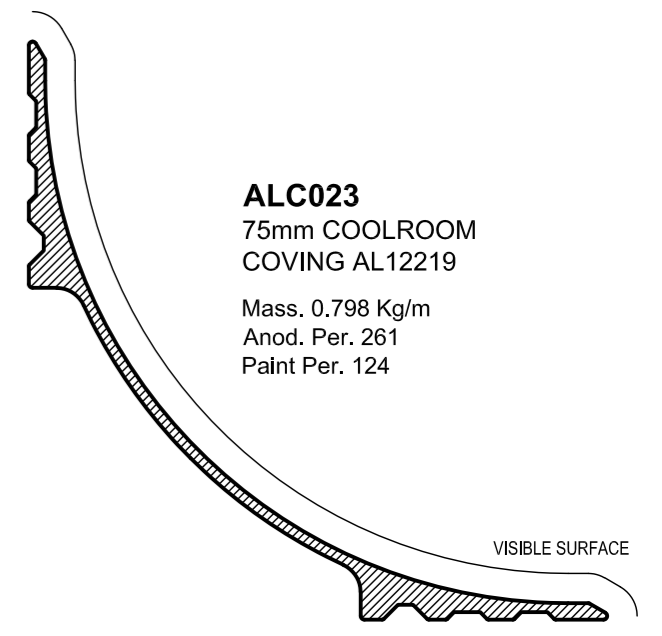

**ALC023**  
75mm COOLROOM COVING AL12219  
Mass. 0.798 Kg/m  
Anod. Per. 261  
Paint Per. 124

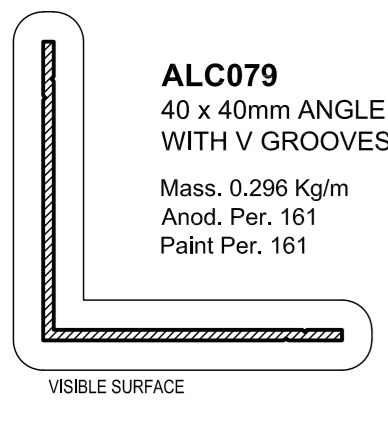

**ALC079**  
40 x 40mm ANGLE WITH V GROOVES  
Mass. 0.296 Kg/m  
Anod. Per. 161  
Paint Per. 161

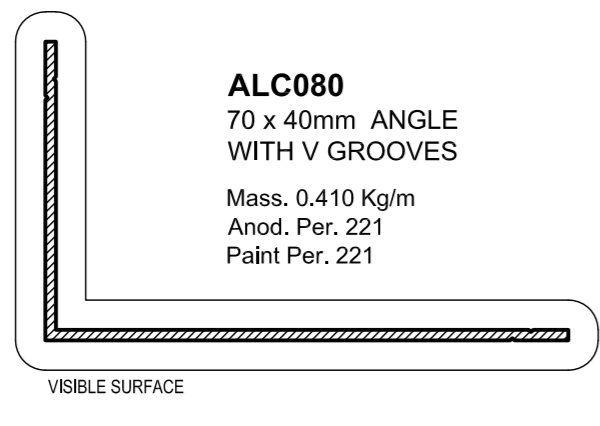

**ALC080**  
70 x 40mm ANGLE WITH V GROOVES  
Mass. 0.410 Kg/m  
Anod. Per. 221  
Paint Per. 221

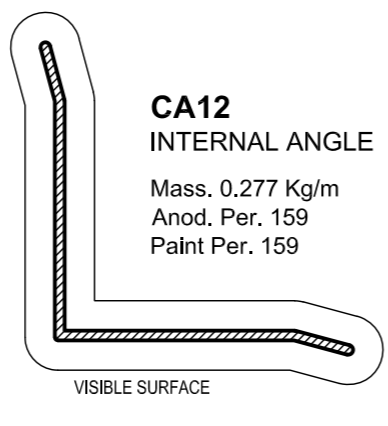

**CA12**  
INTERNAL ANGLE  
Mass. 0.277 Kg/m  
Anod. Per. 159  
Paint Per. 159

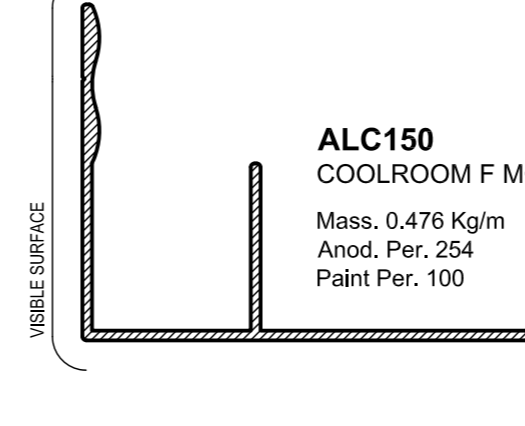

**ALC150**  
COOLROOM F MOULD  
Mass. 0.476 Kg/m  
Anod. Per. 254  
Paint Per. 100



**CR18**  
HEAVY DUTY HINGE BEAM  
Mass. 1.640 Kg/m  
Anod. Per. 253  
NO VISIBLE SURFACE

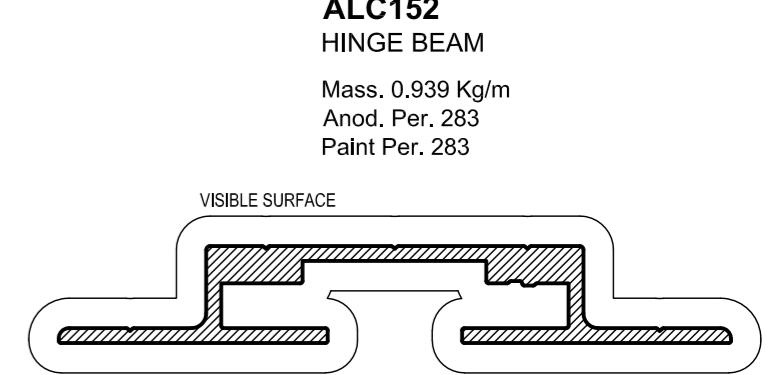

**ALC152**  
HINGE BEAM  
Mass. 0.939 Kg/m  
Anod. Per. 283  
Paint Per. 283

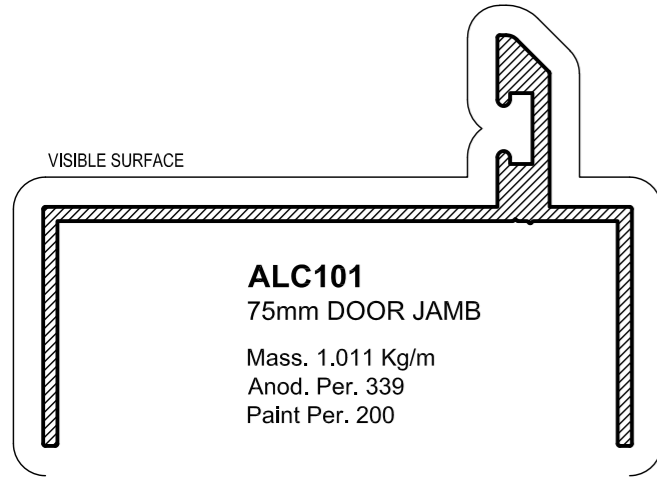

**ALC101**  
75mm DOOR JAMB  
Mass. 1.011 Kg/m  
Anod. Per. 339  
Paint Per. 200

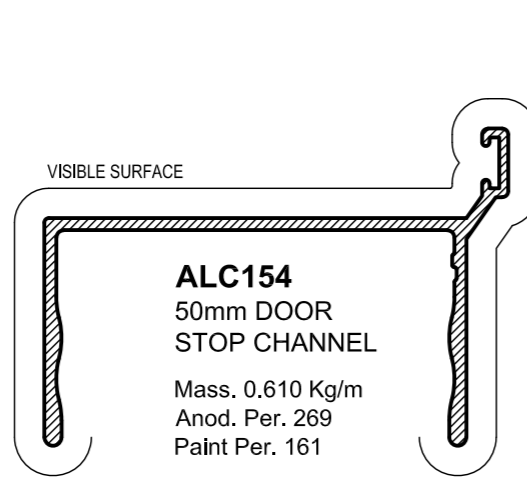

**ALC154**  
50mm DOOR STOP CHANNEL  
Mass. 0.610 Kg/m  
Anod. Per. 269  
Paint Per. 161

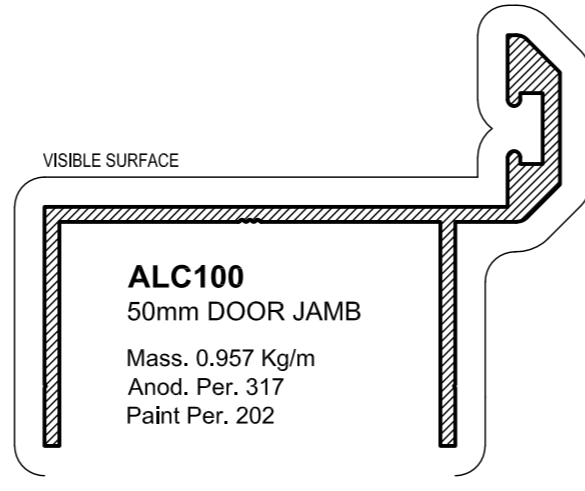

**ALC100**  
50mm DOOR JAMB  
Mass. 0.957 Kg/m  
Anod. Per. 317  
Paint Per. 202

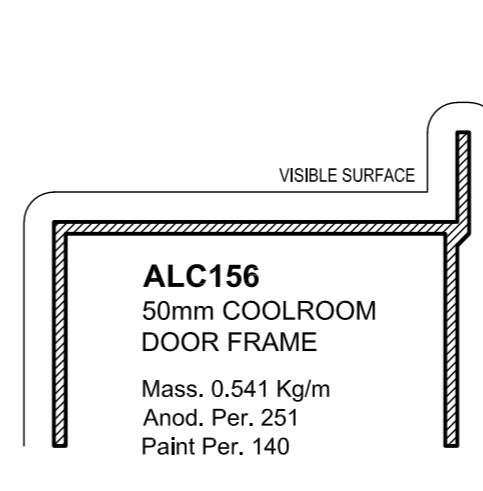

**ALC156**  
50mm COOLROOM DOOR FRAME  
Mass. 0.541 Kg/m  
Anod. Per. 251  
Paint Per. 140

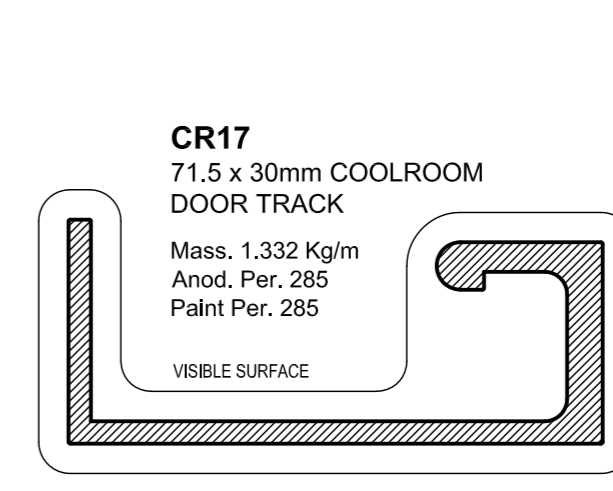

**CR17**  
71.5 x 30mm COOLROOM DOOR TRACK  
Mass. 1.332 Kg/m  
Anod. Per. 285  
Paint Per. 285

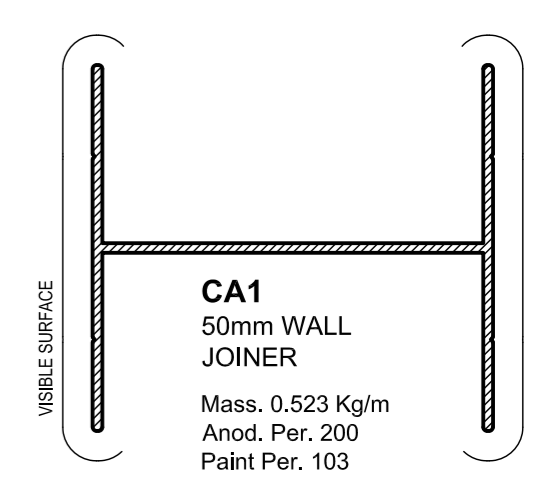

**CA1**  
50mm WALL JOINER  
Mass. 0.523 Kg/m  
Anod. Per. 200  
Paint Per. 103

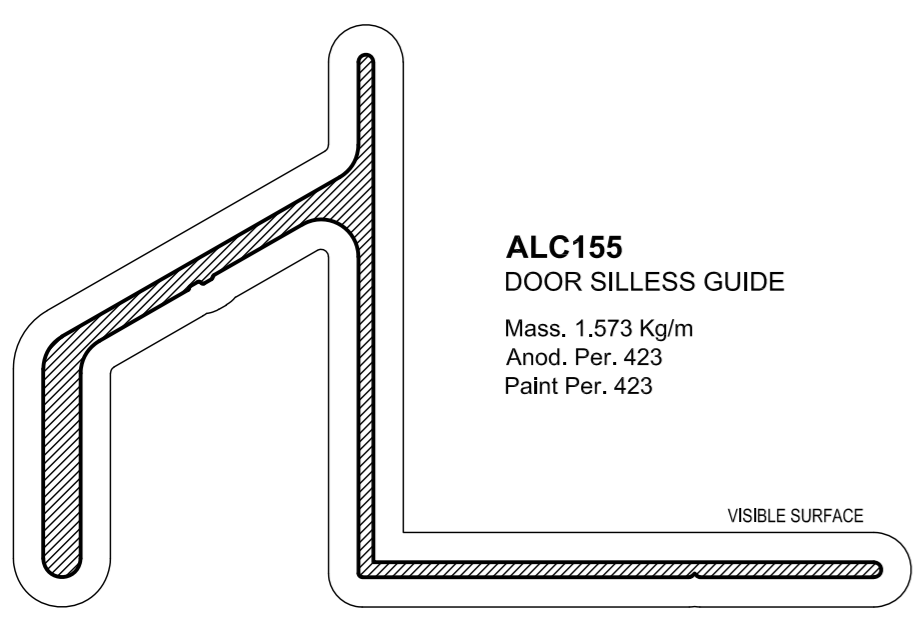

**ALC155**  
DOOR SILLESS GUIDE  
Mass. 1.573 Kg/m  
Anod. Per. 423  
Paint Per. 423

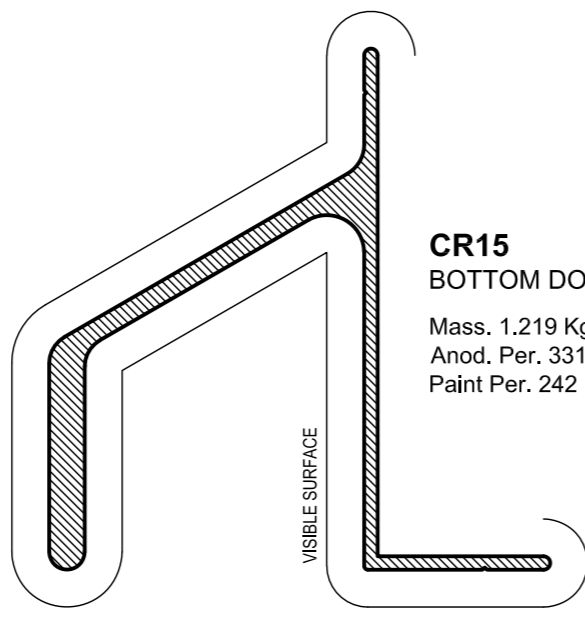

**CR15**  
BOTTOM DOOR TRACK  
Mass. 1.219 Kg/m  
Anod. Per. 331  
Paint Per. 242

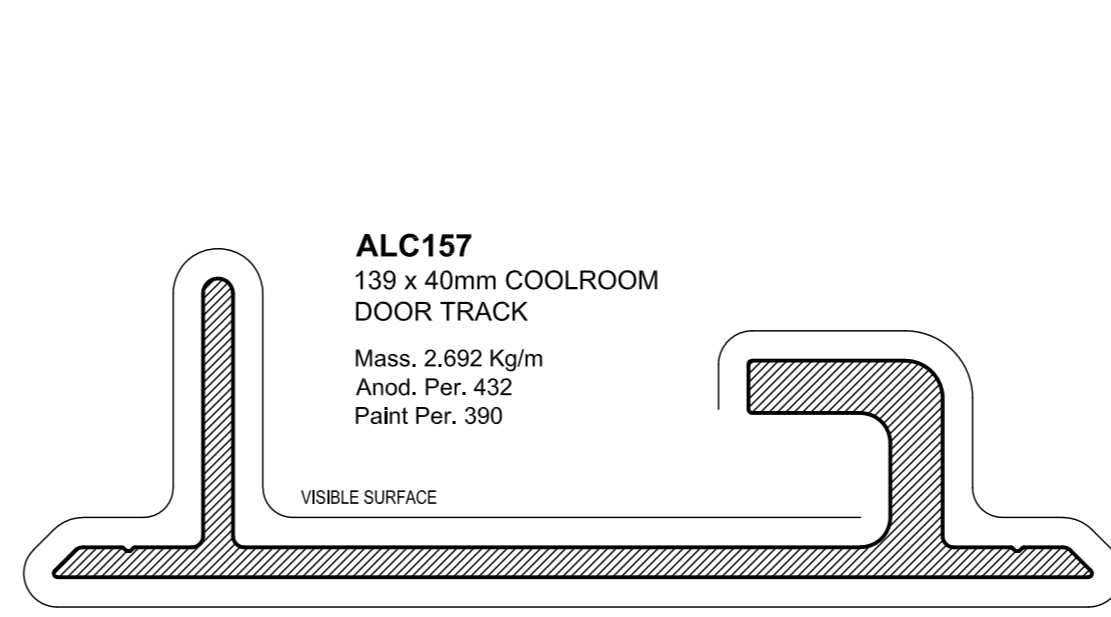

**ALC157**  
139 x 40mm COOLROOM DOOR TRACK  
Mass. 2.692 Kg/m  
Anod. Per. 432  
Paint Per. 390

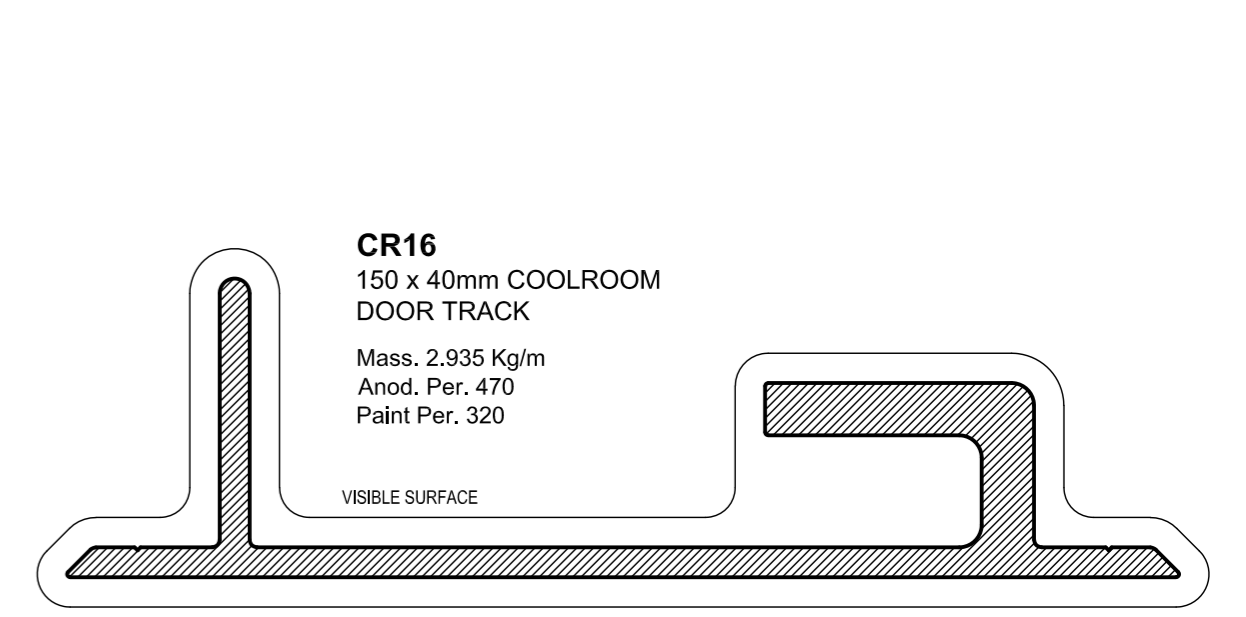

**CR16**  
150 x 40mm COOLROOM DOOR TRACK  
Mass. 2.935 Kg/m  
Anod. Per. 470  
Paint Per. 320